

Vor Auslegung einer automatisierten Verarbeitung des Teils sollte Ruecksprache mit Fa. ARaymond gehalten werden.  
Fully automatic processing of the part requires prior consultation with ARaymond.

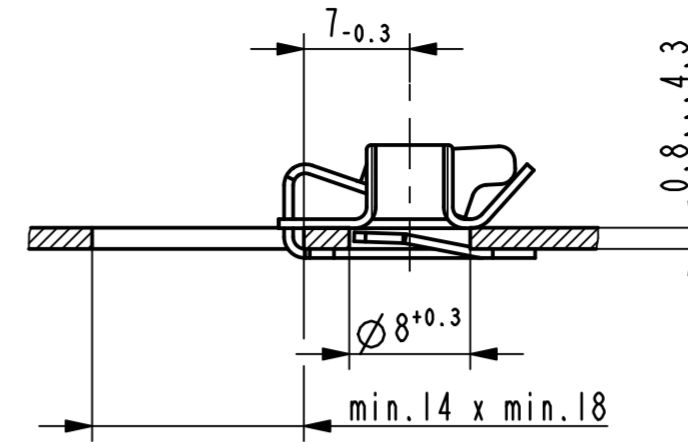

Einbausituation /  
assembly situation  
2:1

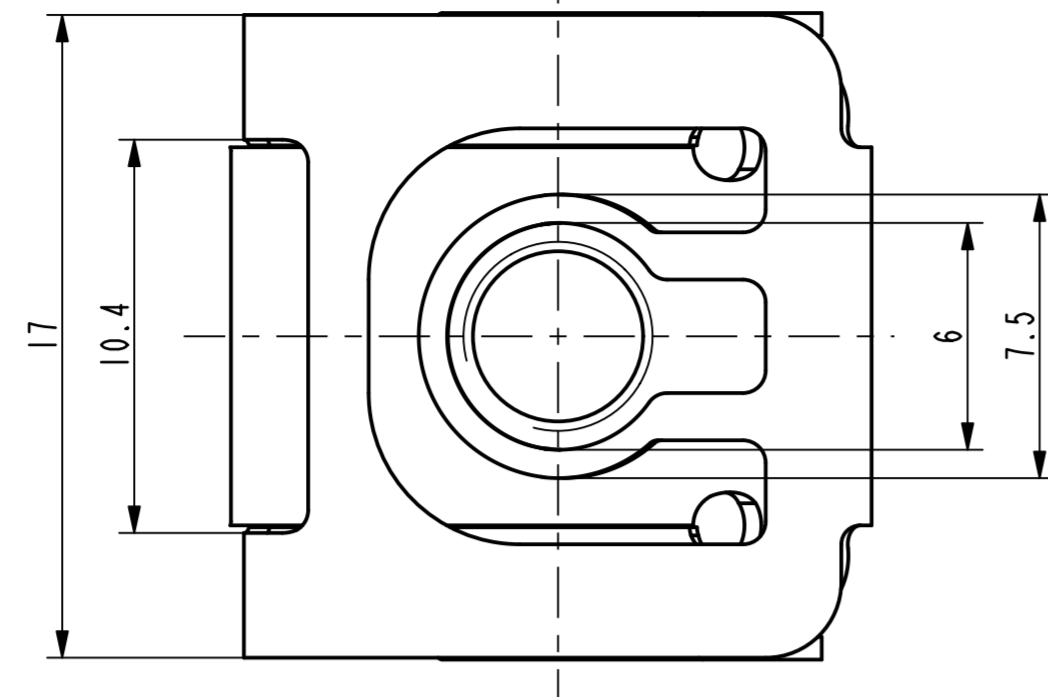
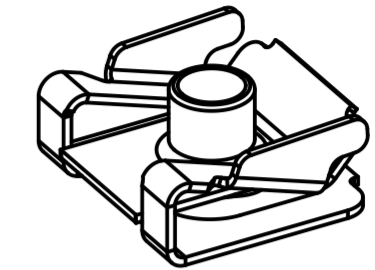

Isometrische Ansicht /  
isometric view  
2:1

Gewindedurchzug kann nur mit lehrenhaltiger  
M5 Schraube geprueft werden /  
the thread strength can only be tested  
with a calibrated M5 screw gauge

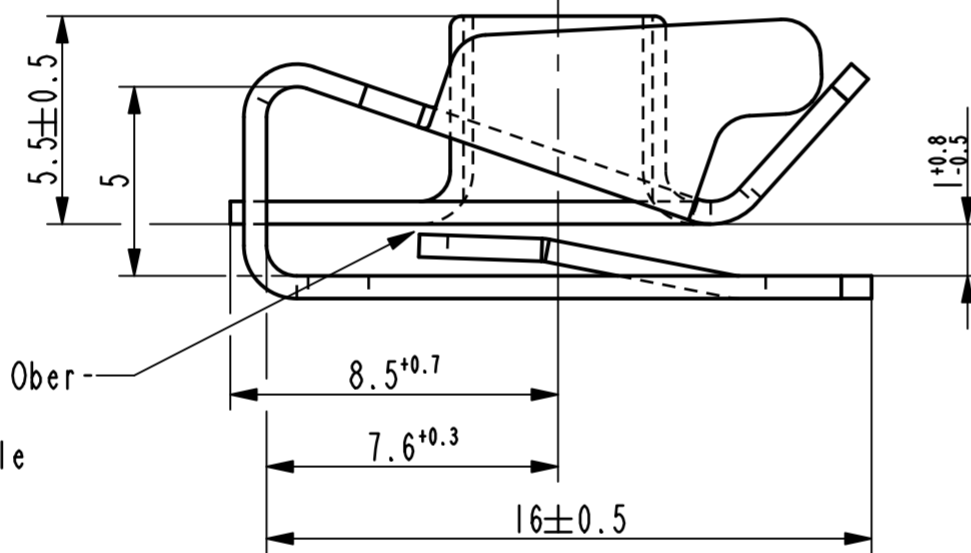

(Ba) Ueberbrueckung der Oeffnung durch Ober-  
flaechenbehandlung zulaessig /  
surface finish bridging permissible

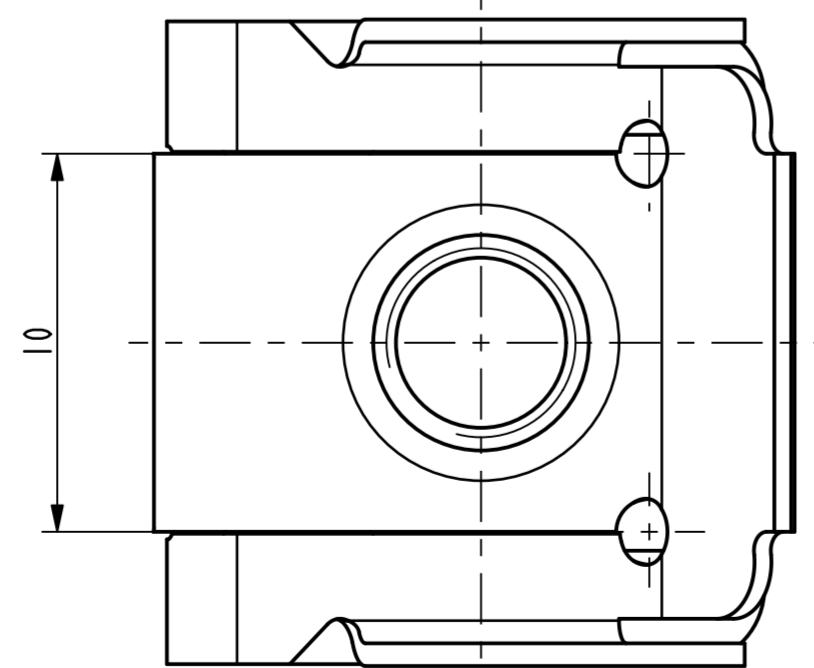

-	-	-	-	-
-	-	-	-	-
-	-	-	-	-
-	-	-	-	-
-	-	-	-	-
-	-	-	-	-
-	-	-	-	-
-	-	-	-	-
-	-	-	-	-
-	-	-	-	-
Ba	2x	Oberflaechenvariante 001 (3000) und 002 (3150) entfernt,	09.12.11	Ru
-	-	Bemerkung hinzug., Schutzrecht DBP 61 entf.	-	-
Rev.	Anzahl/ quantity	Aenderungsbeschreibung / modification description	Datum/date	Name

**ARaymond**  
A RAYMOND GmbH & Co.KG

Teichstrasse 57  
Germany - 79511 Loerrach  
Phone +49 (0) 7621 174-0  
Fax +49 (0) 7621 174-225

Bei Verstaendnisproblemen beantragen Sie bitte beim Absender die deutsche Fassung vor jeder Anwendung.  
"CONDITIONS OF USE"  
This drawing and all information (the "Drawing") disclosed are the exclusive property of ARaymond.  
By using this Drawing the Addressee acknowledges and accepts that this Drawing (1) is covered by ARaymond' intellectual property rights or know-how and (2) is provided under the following conditions who represent a Deposit Agreement.  
This Drawing is for Addressee' internal use only limited to its estimation.  
Without prior written consent of ARaymond, no permission or rights for any purpose, is hereby granted, such as, without any limitation, (1) the copy, in part or entirely, (2) and/or the presentation, in part or entirely, to any other third party outside the Addressee' company or in the company but with no interest (3) and/or the distribution of the Drawing, in part or entirely, in any medium (4) and/or the creation of any derivative work.  
In case of breach of these conditions, Addressee shall indemnify ARaymond from and against all damages (compensatory or consequential), costs, expenses and charges, caused or arising out of or attributable to its willful misconduct, fraud, negligence, infringement of ARaymond' intellectual property rights. If the Addressee does not accept these conditions, please notify ARaymond' sender immediately.

Intellectual property rights	vorbehalten / all rights reserved (Ba)		Classification code	AACCB	
Ersatz fuer/ substitute for	015501.C.01/B/10.05.2005	Entw.Ref./ dev.ref.	Projekt-Nr./ project no.		
Masstab/ scale	5:1	Format	A2		
Allgemeintoleranz/ general tolerance	±0.3		Datum/ date	09.12.2011	
Erstellt von/ prepared by	Ruzicka		Freigegeben/ approved	20111216111403	
Blöckdickel/ mat. thickness DIN EN 10140	0.60	Volumen/ volume (mm³)	354.2	Gewicht/ weight (g)	2.8

Oberfl./  
finish

verzinkt / passiviert farblos  
zinc plated / passivated colourless

Oberfl. Code/  
finish code

3250

Werkstoffbehandl./  
material treatment

zwischenstufenverguetet / austempered  
365 ... 465 HV 5

Werkstoff/  
material

C45E DIN EN 10132-3

Mat. code

1040

Bezeichnung/  
title

Mehrbereichssteckmutter  
fuer Gewinde M5  
sheet metal nut  
for thread M5

Teil-Nr./  
part no.

015501-0-03

Drawing type

C:Customer

Kundenteile-Nr. / customer part no.

-

Blatt / sheet

1 / 1

CAD system & version

ProE WF4

Dateiname / filename

015501-0C00



-	-	-
Teil-Nr. / part no.	Oberflaechen / Farbe / finish / colour	Oberfl. Code/ finish code
Ausfuhrung / Execution		