

DONNÉES TECHNIQUES

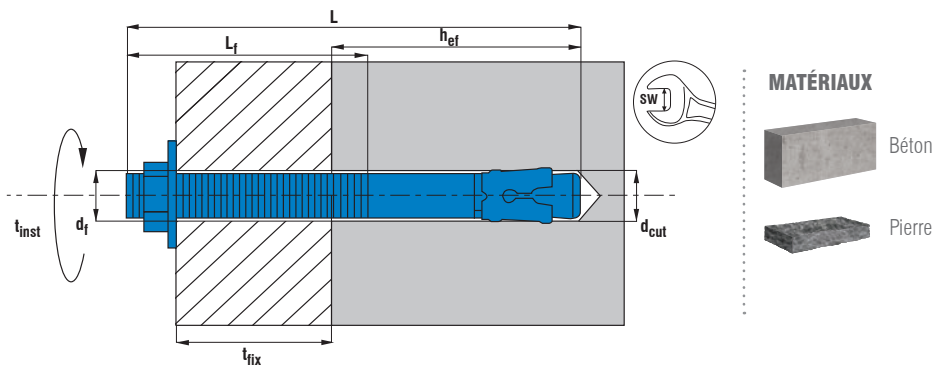

MATÉRIAUX

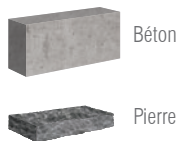

\emptyset	L	t _{fix}	d _{cut}	h ₁	h _{ef}	SW	L ₁	Référence
	mm	mm	mm	mm	mm	mm	mm	
M6*	45	5	6	40	25	10	13.5	BZ-06x45
	55	5	6	50	35	10	21.5	BZ-06x55
	85	30	6	75	35	10	51.5	BZ-06x85
M8	50	2	8	55	40	13	16.5	BZ-08x50
	65	15	8	55	40	13	31.5	BZ-08x65
	70	20	8	55	40	13	36.5	BZ-08x70
	80	30	8	55	40	13	46.5	BZ-08x80
	95	45	8	55	40	13	61.5	BZ-08x95
	100	50	8	55	40	13	66.5	BZ-08x100
	105	55	8	55	40	13	71.5	BZ-08x105
	115	65	8	55	40	13	81.5	BZ-08x115
	130	80	8	55	40	13	96.5	BZ-08x130
165	115	8	55	40	13	100	BZ-08x165	

\emptyset	L	t _{fix}	d _{cut}	h ₁	h _{ef}	SW	L ₁	Référence
M10	65	5	10	65	50	17	27	BZ-10x65
	80	20	10	65	50	17	42	BZ-10x80
	95	35	10	65	50	17	57	BZ-10x95
	110	50	10	65	50	17	72	BZ-10x110
	120	60	10	65	50	17	82	BZ-10x120
M12	150	90	10	65	50	17	100	BZ-10x150
	80	2	12	80	65	19	39	BZ-12x80
	100	20	12	80	65	19	51	BZ-12x100
	120	40	12	80	65	19	71	BZ-12x120
	125	45	12	80	65	19	76	BZ-12x125
	135	55	12	80	65	19	86	BZ-12x135
	180	100	12	80	65	19	100	BZ-12x180
	220	140	12	80	65	19	100	BZ-12x220
	240	160	12	80	65	19	100	BZ-12x240
M16	105	5	16	90	75	24	43	BZ-16x105
	115	15	16	90	75	24	53	BZ-16x115
	125	25	16	90	75	24	63	BZ-16x125
	140	40	16	90	75	24	78	BZ-16x140
	180	80	16	90	75	24	100	BZ-16x180
	200	100	16	90	75	24	100	BZ-16x200
	240	140	16	90	75	24	100	BZ-16x240
M20*	130	5	20	135	100	30	65	BZ-20x130
	160	35	20	135	100	30	95	BZ-20x160
	215	90	20	135	100	30	100	BZ-20x215

* hors agrément