

Vor Auslegung einer automatisierten Verarbeitung des Teils sollte Rücksprache mit Fa. ARaymond gehalten werden.
Fully automatic processing of the part requires prior consultation with ARaymond.

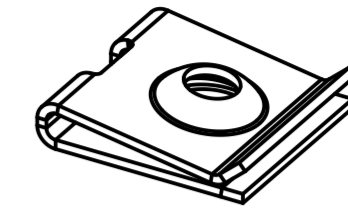

Isometrische Ansicht /
isometric view
2:1

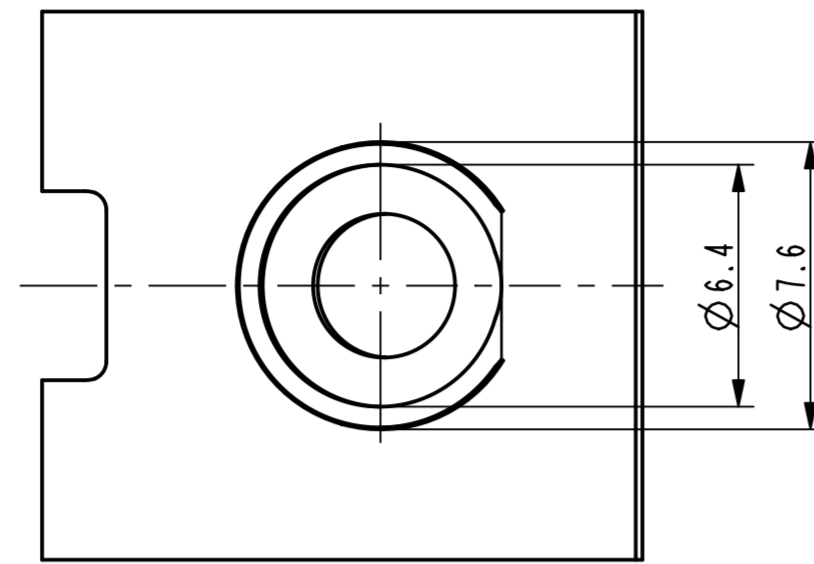
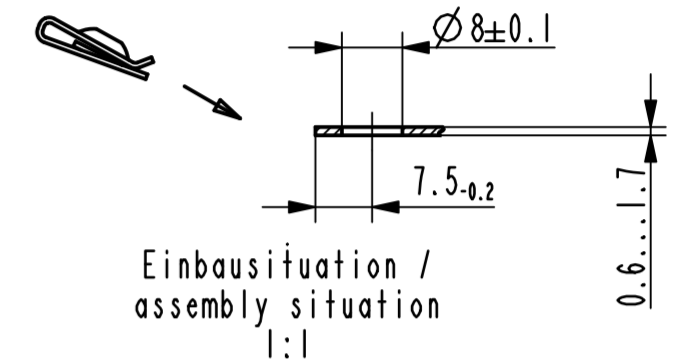

Einbausituation /
assembly situation
1:1

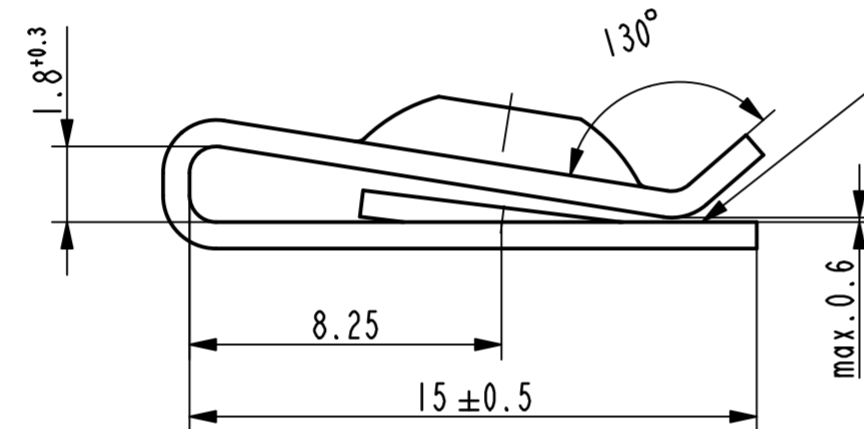

Ueberbrueckung der Oeffnung durch
Oberflaechenbeschichtung zulaessig /
surface finish bridging permissible

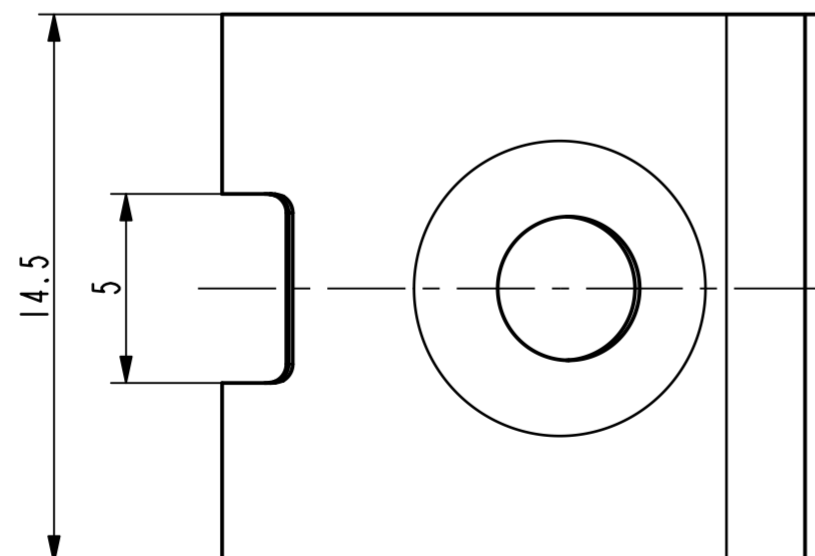

-	-	-	-	-
-	-	-	-	-
-	-	-	-	-
-	-	-	-	-
-	-	-	-	-
-	-	-	-	-
-	-	-	-	-
-	-	-	-	-
-	-	-	-	-
-	-	-	-	-

Ad	-	Zeichnung ueberarbeitet nach AR Gruppenstandard, Teil unveraendert	21.07.14	Ru
Rev.	Anzahl/ quantity	Aenderungsbearbeitung / modification description	Datum/date	Name

ARaymond
A RAYMOND GmbH & Co.KG
Teichstrasse 57
Germany - 79511 Loerrach
Phone +49 (0) 7621 174-0
Fax +49 (0) 7621 174-225

Bei Verstaendnisproblemen beantragen Sie bitte beim Absender die deutsche Fassung vor jeder Anwendung.
"CONDITIONS OF USE"
This drawing and all information (the "Drawing") disclosed are the exclusive property of ARaymond.
By using this Drawing the Addressee acknowledges and accepts that this Drawing
(1) is covered by ARaymond' intellectual property rights or know-how and
(2) is provided under the following conditions who represent a Deposit Agreement.
This Drawing is for Addressee' internal use only limited to its estimation.
Without prior written consent of ARaymond, no permission or rights for any purpose, is hereby granted, such as, without any limitation,
(1) the copy, in part or entirely,
(2) and/or the presentation, in part or entirely, to any other third party outside the Addressee' company or in the company but with no interest
(3) and/or the distribution of the Drawing, in part or entirely, in any medium
(4) and/or the creation of any derivative work.
In case of breach of these conditions, Addressee shall indemnify ARaymond from and against all damages (compensatory or consequential),
costs, expenses and charges, caused or arising out of or attributable to its willful misconduct, fraud, negligence, infringement of
ARaymond' intellectual property rights. If the Addressee does not accept these conditions, please notify ARaymond' sender immediately.

Intellectual property rights	vorbehalten / all rights reserved		Classification code	AABDC
Ersatz fuer/ substitute for	015617.C.01/Ac/20.11.2006	Entw.Ref./ dev.ref.	Projekt-Nr./ project no.	
Masstab/ scale	5:1	Allgemeintoleranz/ general tolerance	Datum/ date	21.07.2014
Format	A2	Erstellt von/ prepared by	Ruzicka	
Projektion / projection	ALL DIMENSIONS ARE IN MILLIMETERS	Freigegeben/ approved	20140725085356	
Blechklaesse/ mat. thickness DIN EN 10140	0.70	Volumen/ volume (mm³)	296.3	Gewicht/ weight (g)
				2.4

Oberfl./
finish
metallhaltige Korrosionsschutzbeschichtung, Farbe silver, GZ
metallic corrosion protection coated, colour silver, lubricated
Oberfl. Code/
finish code
4001

Werkstoffbehandl./
material treatment
zwischenstufenverguetet / austempered
225 ... 325 HV 5

Werkstoff/
material
C67S DIN EN 10132-4
Mat. code
1000

Bezeichnung/
title
Blechmutter
fuer Gewindeformschraube M5
sheet metal nut
for thread form screw M5

Teil-Nr./
part no.
015617-0-02
Drawing type
C:Customer

Kundenteile-Nr. / customer part no. -
Blatt / sheet 1 / 1
CAD system & version Crea2
Dateiname / filename 015617-0C00

015617-0-03	verzinkt / passiviert farblos zinc plated / passivated colourless	3250
Teil-Nr. / part no.	Oberflaechen / Farbe / finish / colour	Oberfl. Code/ finish code
Ausfuhrung / Execution		