

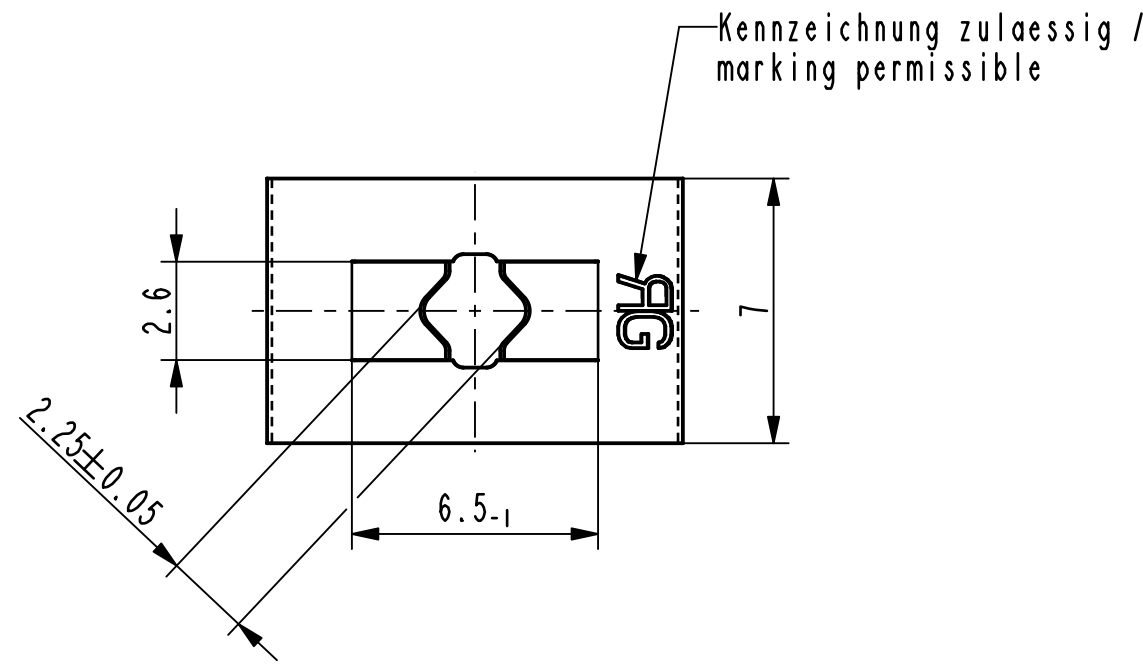

Isometrische Ansicht /
 isometric view
 2:1

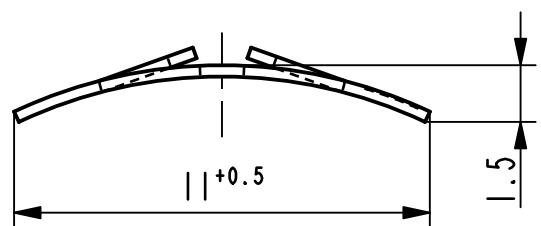

Vor Auslegung einer automatisierten Verarbeitung des Teils sollte Ruecksprache mit Fa. ARaymond gehalten werden.
 Fully automatic processing of the part requires prior consultation with ARaymond.

-	-	-	-	-
-	-	-	-	-
-	-	-	-	-
-	-	-	-	-
-	-	-	-	-
-	-	-	-	-
-	-	-	-	-
-	-	-	-	-
-	-	-	-	-
-	-	-	-	-
-	-	-	-	-
-	-	-	-	-
Bb	-	Oberflaechenvariante entfernt (3000)	20.07.11	mj

Rev.	Anzahl/ quantity	Aenderungsbearbeitung / modification description	Datum/date	Name



Teichstrasse 57
 Germany - 79511 Loerrach
 Phone +49 (0) 7621 174-0
 Fax +49 (0) 7621 174-225

Bei Verstaendnisproblemen beantragen Sie bitte beim Absender die deutsche Fassung vor jeder Anwendung.
 "CONDITIONS OF USE"
 This drawing and all information (the "Drawing") disclosed are the exclusive property of ARaymond.
 By using this Drawing the Addressee acknowledges and accepts that this Drawing
 (1) is covered by ARaymond' intellectual property rights or know-how and
 (2) is provided under the following conditions who represent a Deposit Agreement.
 This Drawing is for Addressee' internal use only limited to its estimation.
 Without prior written consent of ARaymond, no permission or rights for any purpose, is hereby granted, such as, without any limitation,
 (1) the copy, in part or entirely
 (2) and/or the presentation, in part or entirely, to any other third party outside the Addressee' company or in the company but with no interest
 (3) and/or the distribution of the Drawing, in part or entirely, in any medium
 (4) and/or the creation of any derivative work.
 In case of breach of these conditions, Addressee shall indemnify ARaymond from and against all damages (compensatory or consequential), costs, expenses and charges, caused or arising out of or attributable to its willful misconduct, fraud, negligence, infringement of ARaymond' intellectual property rights. If the Addressee does not accept these conditions, please notify ARaymond' sender immediately.

Intellectual property rights	vorbehalten / all rights reserved		Classification code	EAAB-
Ersatz fuer/ substitut for	011748_c_01/Ba/03.01.2007	Entw.Ref./ dev.ref.	Projekt-Nr./ project no.	

Masstab/ scale	Format	Allgemeintoleranz/ general tolerance	Datum/ date	20.07.2011
5:1	A3	± 0.25	Erstellt von/ prepared by	M. Junge

Projektion / projection	ALL DIMENSIONS ARE IN MILLIMETERS	Freigegeben/ approved	20110720113634	
	Blechedicke/ mat. thickness DIN EN 10140	0.30	Volumen/ volume (mm³)	22.0
			Gewicht/ weight (g)	0.2

Oberfl./ finish	metallhaltige Korrosionsschutzbeschichtung, Farbe schwarz, GZ metallic corrosion protection coated, colour black, lubricated	Oberfl. Code/ finish code	5453
--------------------	---	------------------------------	------

Werkstoffbehandl./ material treatment	zwischenstufenverguetet / austempered 435 ... 535 HV 3		
--	---	--	--

Werkstoff/ material	C67S DIN EN 10132-4	Mat. code	1000
------------------------	---------------------	-----------	------

Benennung/
title
Federmutter
 fuer Bolzen Ø2.5h11
spring nut
 for bolt Ø2.5h11

Teil-Nr./ part no.	011748-0-02	Drawing type	C:Customer
-----------------------	-------------	--------------	------------

011748-0-03	verzinkt / passiviert farblos zinc plated / passivated colourless	3250
Teil-Nr. / part no.	Oberflaeche / Farbe / finish / colour	Oberfl. Code/ finish code
Ausfuehrung / Execution		

Kundenteile-Nr. / customer part no.	-	Blatt / sheet	1 / 1
CAD system & version	ProE WF4	Dateiname / filename	011748-0C00